

915

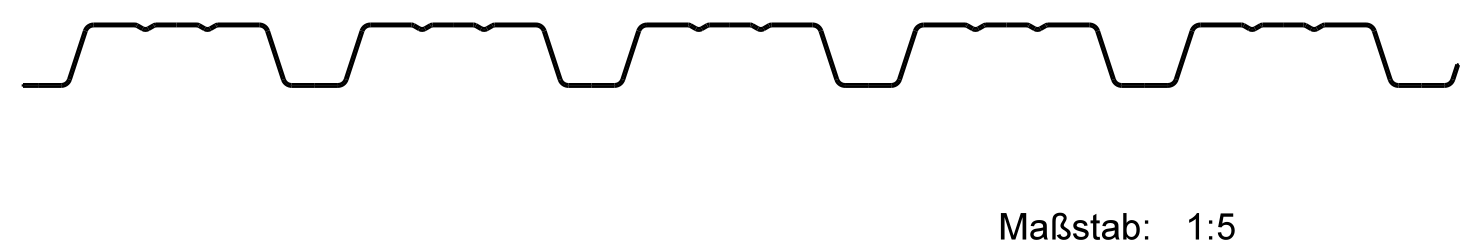
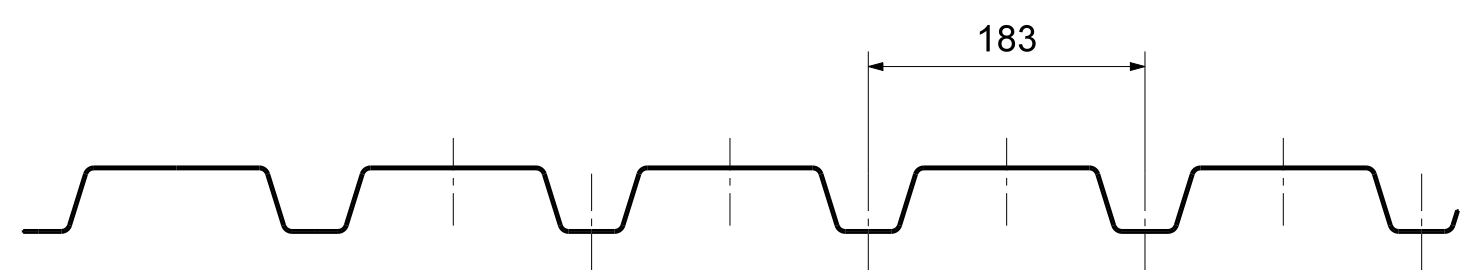
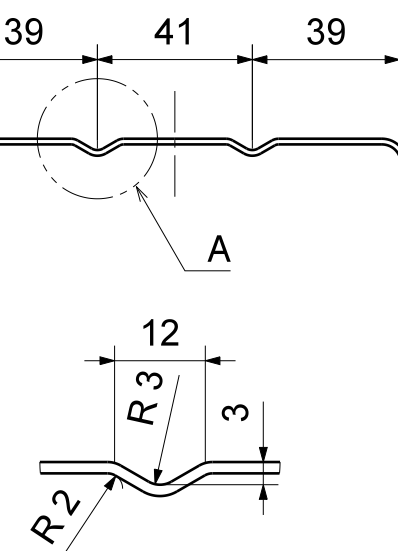
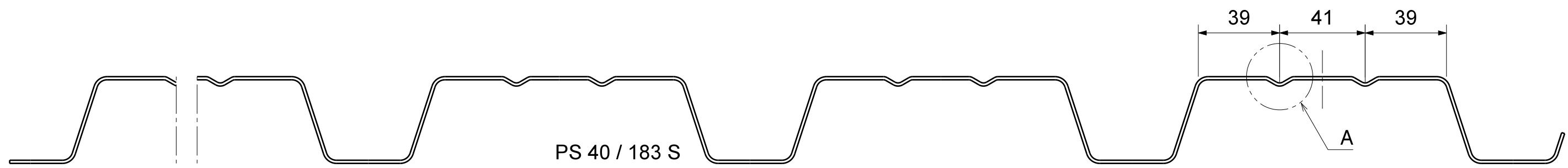
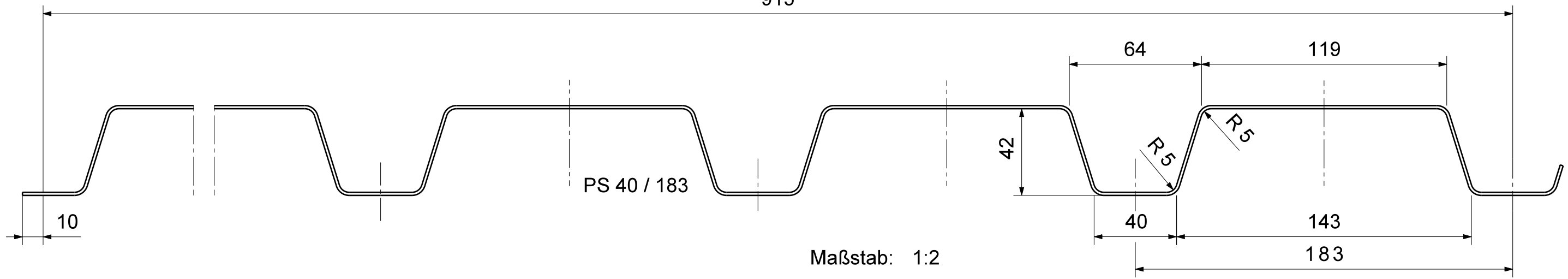

Bemaßung und Toleranzen nach DIN 18807 Teil 1 bzw EPAQ bei max. Blechdicke von 1,5 mm

Blechdicke: 0,63 - 1,5 mm

Flachblech: 1.241 ⁺⁵ mm

				Maßstab: 1:2 (1:5)	
				Werkstoff: S320 GD+Z	
				Trapezprofil PS 40 / 183	
				Trapezprofil PS 40 / 183 S	
					
				A3 Blatt /.	
Zust	Änderung	Datum	Name	Schutzvermerk nach DIN 34 beachten	